

Butterfly valves, full bore

welding/welding, EN (DIN), DN 300-800 $\Delta p = 25$ bar control

Properties

Body:	DN 300 - 500 Steel, EN 10217-2 P235GH (1.0345) DN 600 - 800 Steel, EN 10028-3 P355NL1 (1.0566)
Disc:	EN GX5CrNiMo19-11-2 (1.4408)
Seat:	Alloy 825
Shaft:	EN X3CrNiMoN27-5-2 (1.4460)
Shaft seal:	Graphite
Bearings:	PTFE+AISI 316 net
Welding ends:	ISO 6761
Operation:	Valves are available with manual gear, electric actuator or hydraulic actuator.



Operating conditions

Body:	PN 25
Trim:	PN 25
Temperature:	-40 °C - +250 °C
Leakage rate:	B (by request rate A)

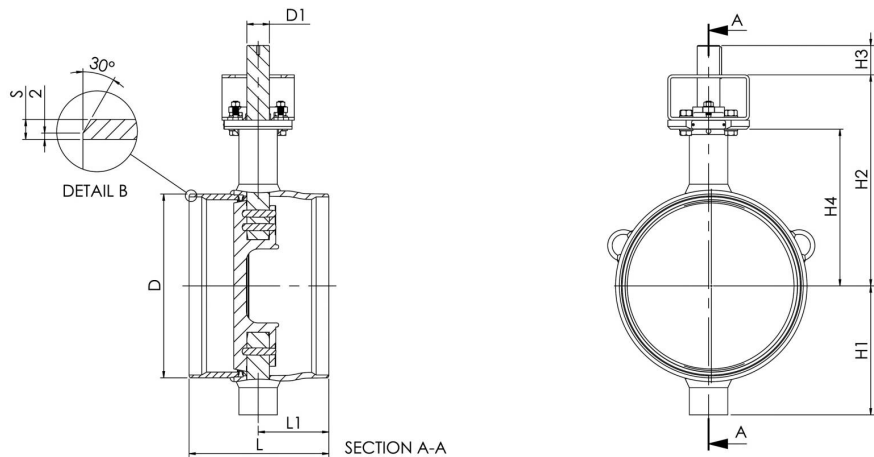

Product no.	DN	L	L1	H1	H2	H3	H4	D	D1	S	Kv	Kg
BFC300W2	300	270	110	247	435	65	315	323,9	35	5,6	6200	61
BFC350W2	350	290	134	255	445	65	325	355,6	35	5,6	7400	75
BFC400W2	400	310	157	285	467	65	347	406,4	40	6,3	9800	96
BFC500W2	500	350	153	360	528	80	408	508	50	6,3	15600	167
BFC600W2	600	390	184	440	575	110	450	610	60	7,1	22700	280
BFC700W2	700	430	203	495	625	110	501	711	70	8	31300	420
BFC800W2	800	470	226	581	733	130	573	813	90	8,8	40700	670