

Steel ball valves, reduced bore

welding/welding, EN (DIN), DN 700-800

Properties

Body:	Steel, P355 NL1 (1.0566)/GP240GH (1.0619)
Ball:	Steel + stainless plating, ASTM A350 LF2 +Ni
Stem:	Stainless steel, EN X8CrNiS18-9 (1.4305)
Stem seals:	FPM
Ball seals:	Carbonized PTFE
Standard equipment:	As standard valve is delivered with lifting lugs, drain valve and mounting stand.
Operation:	Valves are available with manual gear, electric actuator or hydraulic actuator.



Operating conditions

-30°C - +200°C

Below 0 °C contact manufacturer

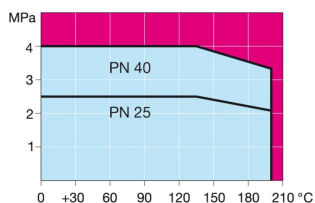

Not for steam

DN 700 - 800

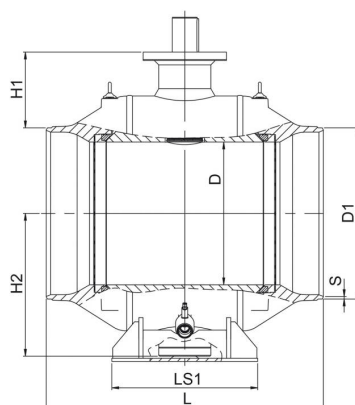

DN	PN	Product no.	D	D1	D2	D3	S	H1	H2	HS1	LS1	LS2	L	ISO 5211	Kv	Kg
700	25	100 700	589	711	965	100	8	336	592	616	560	965	1205	F35	42000	2500
800	25	100 800	684	813	1125	120	8,8	365	684	709	700	1028	1330	F35	55000	3650

Available also PN40