

# Steel ball valves, reduced bore

welding/welding, EN (DIN), DN 10-250

## Properties

Body:	Steel, EN 10217-2 P235GH (1.0345)
Ball:	Stainless steel, EN X5CrNi18-10 (1.4301)
Stem:	Stainless steel, EN X8CrNiS18-9 (1.4305)
Stem seals:	FPM
Ball seals:	Carbonized PTFE
Operation:	DN 10 - 250 with galvanized steel handle We recommend manual gear operation for sizes DN200 and larger



## Operating conditions

-30°C - +200°C  
Below 0 °C contact manufacturer

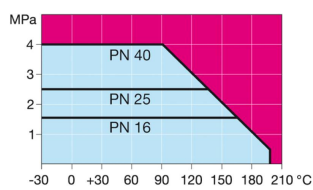

Not for steam

DN 10 - 150

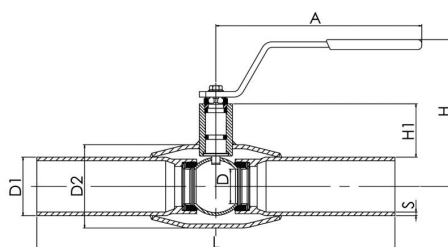

DN 200 - 250

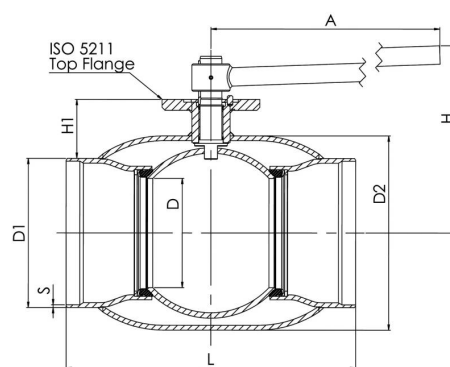

DN	PN	Product no.	D	D1	D2	S	H	H1	A	L	Kv	Kg
10	40	100 010	10	17,2	33,7	2	100	23	140	230	8	0,5
10	40	100 010/H	10	17,2	33,7	2	125	50	140	230	8	0,5
15	40	100 015	10	21,3	33,7	2	100	23	140	230	8	0,5
15	40	100 015/H	10	21,3	33,7	2	125	50	140	230	8	0,5
20	40	100 020	15	26,9	42,4	2,3	105	24	140	230	14	0,7
20	40	100 020/H	15	26,9	42,4	2,3	129	50	140	230	14	0,7
25	40	100 025	20	33,7	48,3	2,6	105	40	150	230	25	1
25	40	100 025/H	20	33,7	48,3	2,6	112	49	150	230	25	1
32	40	100 032	25	42,4	60,3	2,6	105	39	150	260	41	1,4
32	40	100 032/H	25	42,4	60,3	2,6	115	48	150	260	41	1,4
40	40	100 040	32	48,3	76,1	2,6	125	59	190	260	65	1,9
50	40	100 050	40	60,3	88,9	2,9	135	59	190	300	103	2,7
65	25	100 065	50	76,1	114,3	2,9	180	71	280	300	180	4,2
80	25	100 080	65	88,9	139,7	3,2	190	77	280	300	290	5,5
100	25	100 100	80	114,3	168,3	3,6	230	97	280	325	470	8,3
125	25	100 125	100	139,7	177,8	4	245	96	420	325	830	13,3
150	25	100 150	125	168,3	219,1	4,5	280	103	600	350	1150	18,5
200	25	100 200	150	219,1	273	4,5	280	92	870	400	1750	39
250	25	100 250	200	273	355,6	5	350	108	1200	530	3200	74

H=Higher stem