

ARTICULO: 2103 Válvula de mariposa tipo wafer. Butterfly valve wafer type.

Características

1. Válvula de mariposa tipo wafer.
2. Cuerpo de fundición GG-20 para montaje entre bridas ANSI 150 y DIN PN 10/16.
3. Elastómero de EPDM.
4. Disco de hierro fundido GGG-40.
5. Brida montaje actuadores según ISO 5211 – DIN 3337.
6. Longitud entre caras según UNE EN 558-1 Serie 20 (DIN 3202 K1).
7. Pintado con pintura Epoxi.
8. Temperatura de trabajo -20°C +120 °C.
9. Máxima presión de trabajo:
16 bar (medidas 2” a 12”)
10 bar (medidas 14” a 20”)

Features

1. Butterfly valve wafer type
2. GG20 CastIron bodyallows installation in ANSI 150 and DIN PN 10/16 pipeflanges.
3. EPDM bodyseat.
4. Butterflymade in Iron GGG40.
5. Actuatormounting plate according to ISO 5211– DIN 3337.
6. Face to face according to UNE EN 5581 Series 20 (DIN 3202 K1).
7. Epoxy coating.
8. WorkingTemperature20°C +120 °C.
9. Maximum working pressure:
16 bar(sizes 2”to 12”)
10 bar (sizes 14” to 20”)

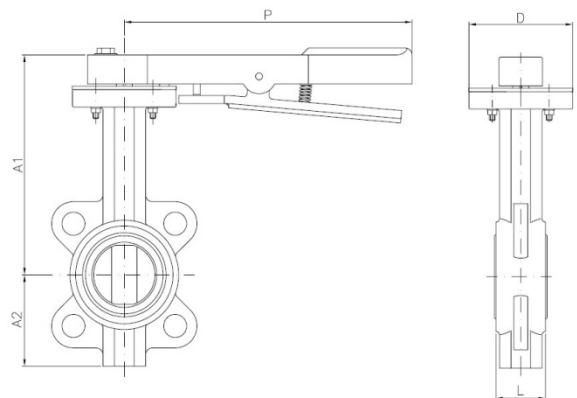
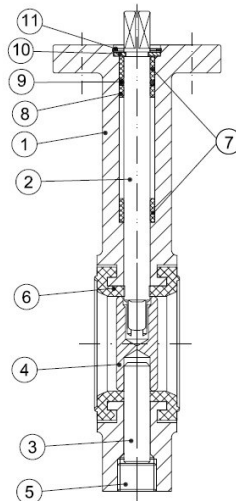

Nº	Denominación / Name	Material	Acabado Superficial / Surface Treatment
1	Cuerpo / Body	Fundición GG-20 / Cast iron GG-20	Pintado Epoxi / Epoxy Painted
2	Eje / Stem	Acero Inox AISI 416 / SS 416	-----
3	Pivote / Pivot	Acero Inox AISI 416 / SS 416	-----
4	Disco / Disc	Fund. GGG-40 / Dúctil Iron GGG-40	Cincado / Zinc Plated
5	Tapón / Plug	Acero Carbono / Carbon Steel	Cincado / Zinc Plated
6	Elastómero / Seat	EPDM	-----
7	Casquillo / Bush	PTFE + Grafito	-----
8	Casquillo / Bush	PTFE + Grafito	-----
9	Tórica / O' ring	NBR	-----
10	Arandela / Washer	Bronze	-----

11	Seguro / Stop Ring	Acero / Steel	-----
12	Placa dentada / Plate	Acero / Steel	Cincado / Zinc Plated
13	Palanca / Handle	Aluminio / Cast iron GG-20	Pintado Epoxi / Epoxy Painted

DIMENSIONES GENERALES / GENERAL DIMENSIONS

Ref	Medida/ Size	DN	PN	L	Dimensiones / Dimensions (mm)				Peso/ Weight (kg)
					A1	A2	J	P	
2103 09	2"	50	16	43	238	70	***	180	2,8
2103 10	2 ½"	65	16	46	238	80	***	180	3,3
2103 11	3"	80	16	46	238	100	***	180	3,8
2103 12	4"	100	16	52	270	115	***	215	6,1
2103 13	5"	125	16	56	300	125	***	215	7,4
2103 14	6"	150	16	56	300	145	***	215	8,9
2103 16	8"	200	16	60	300	150	***	300	14,4
2103 18	10"	250	16	68	330	200	***	300	21,2
2103 20	12"	300	16	78	360	250	240	290	37,5
2103 22	14"	350	10	78	390	260	257	290	56,1
2103 24	16"	400	10	102	420	300	257	290	77,6
2103 26	18"	450	10	114	445	330	306	400	118,5
2103 28	20"	500	10	127	480	370	306	400	151,5

*** Nota: De 2 a 6 Maneta de aluminio / From 2" to 6" Aluminium handle.
De 8 a 10 Maneta de fundición de hierro / From 8" to 10" cast iron handle.
A partir de 12 operación mediante reductor manual / From 12", handling by gear box.

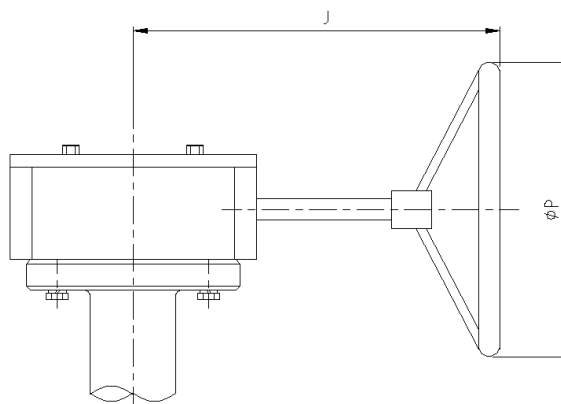

Dimensiones de brida superior / Top flange dimensions

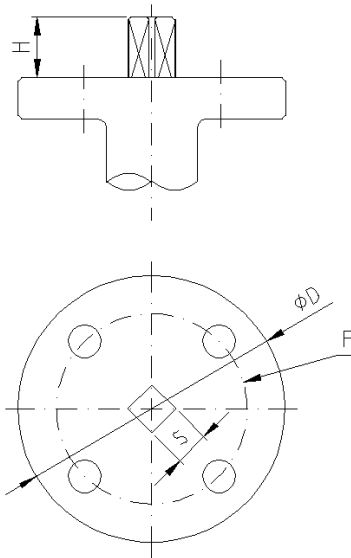

Top flange dimensions						
Article	DN	F (ISO5211)	S	D	H	Torque N.m
2103 09	50	F05	11	65	30	12
2103 10	65	F05	11	65	30	20
2103 11	80	F05	11	65	30	27
2103 12	100	F07	14	90	30	39
2103 13	125	F07	14	90	30	58
2103 14	150	F07	14	90	30	90
2103 16	200	F07/F10	17	125	30	120
2103 18	250	F10	22	125	40	180
2103 20	300	F10/F12	22	150	40	340
2103 22	350	F12	22	150	45	640
2103 24	400	F14	27	175	45	805
2103 26	450	F14	27	175	45	1100
2103 28	500	F14	36	175	45	1500

Perdidas de Carga (Cv) segun posición del disco / Head losses according to disc position

DN	Posición del Disco (grados) / Disc Position (degrees)								
	90°	80°	70°	60°	50°	40°	30°	20°	10°
50	144	114	84	61	43	27	16	7	1
65	282	223	163	107	67	43	24	11	1.5
80	461	364	267	154	96	61	35	15	2
100	841	701	496	274	171	109	62	27	3
125	1376	1146	775	428	268	170	98	43	5
150	1850	1542	1025	567	354	225	129	56	6
200	3316	2842	1862	1081	680	421	241	102	12
250	5430	4525	2948	1710	1076	667	382	162	19
300	8077	6731	4393	2563	1594	1005	555	235	27
350	10538	8874	5939	3384	2149	1320	756	299	34
400	13966	11761	7867	4483	2847	1749	1001	397	45
450	17214	14496	10065	5736	3643	2237	1281	507	58
500	22339	18812	12535	7144	4536	2786	1595	632	72

VALORES DE Cv / Cv VALUES

Cv = Es la cantidad de galones por minuto (gpm) que pasará a través de la válvula generando una pérdida de carga de 1 psi.

Cv = The flow rate of water (g.p.m.) which generates a pressure drop of 1 psi across the valve.

Medidas de Precaución para instalación / Precautions measures for Installation

1. No instale la válvula en posición totalmente cerrada / Do not install the butterfly valve in total closed position
2. Verifique el buen paralelismo de las bridas / Check the good parallelism of the flanges
3. No coloque otras juntas entre las bridas / Do not insert other gaskets between flange and valve

